

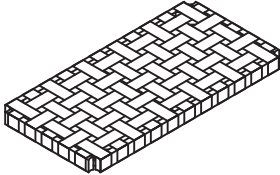

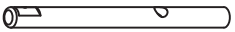

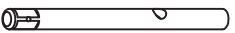
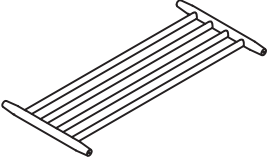

# ASSEMBLY INSTRUCTION

ITEM : Oak/Nylon-Bench

NO.	PARTLIST	QTY
1	 BENCH TOP	1PC
2	 LEG	2PCS
3	 LEG	2PCS
4	 BOTTOM SUPPORT FRAME	1PC
NO.	HARDWARE	QTY
A	 BOLT M6 X 80	4PCS
B	 SPRING WASHER	4PCS
C	 FLAT WASHER	4PCS
D	 NUT	4PCS
E	 WRENCH	1PC
F	 SCREW M3.5 X 40	4PCS
G	 FELT MA	4PCS

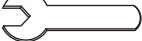
## STEP 1

Put bolt (A) into legs (2) and (3).

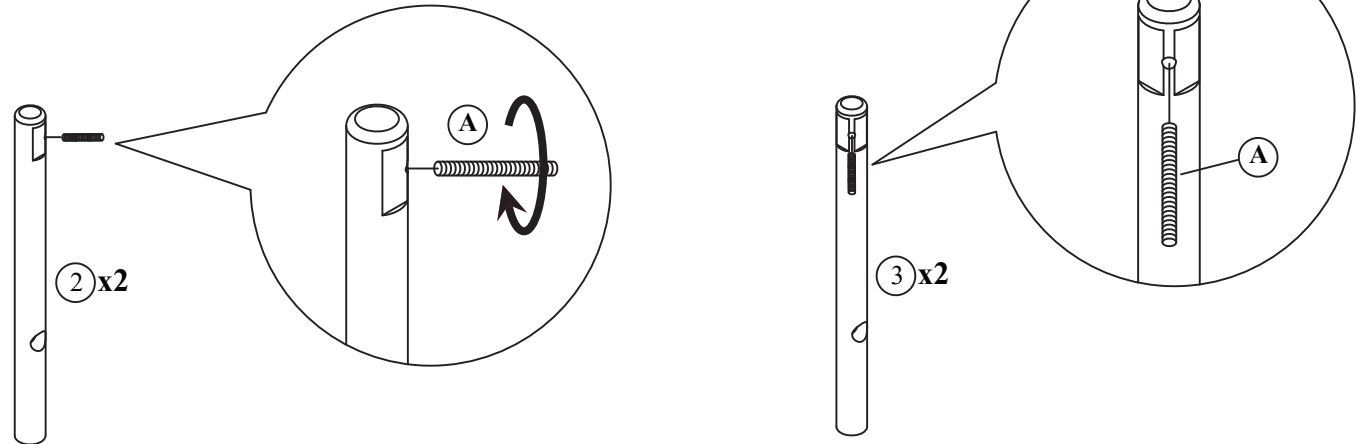

## STEP 2

Keep seat vertical, Fix 2 legs (2) and (3) on seat frame, by using flat washer (C), spring washer (B), nut (D) and wrench (E). Then fix bottom support frame (4) by screw (F).

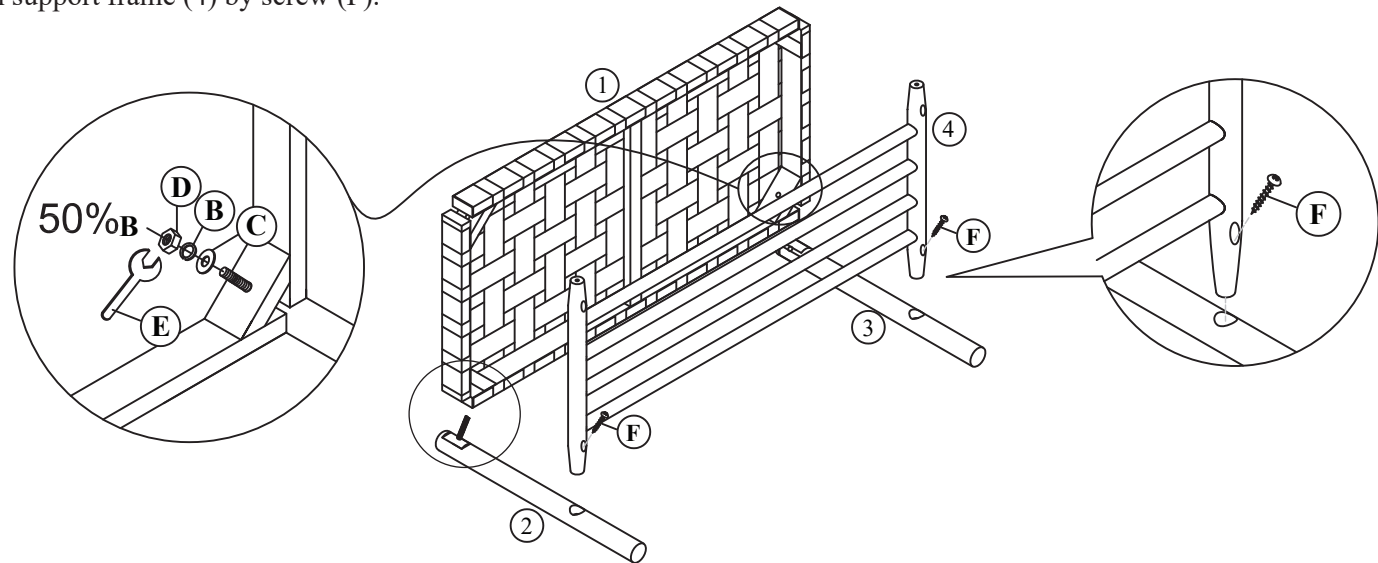

### STEP 3

Assemble remaining legs (2) and (3) and fix them with support frame same as step 2.

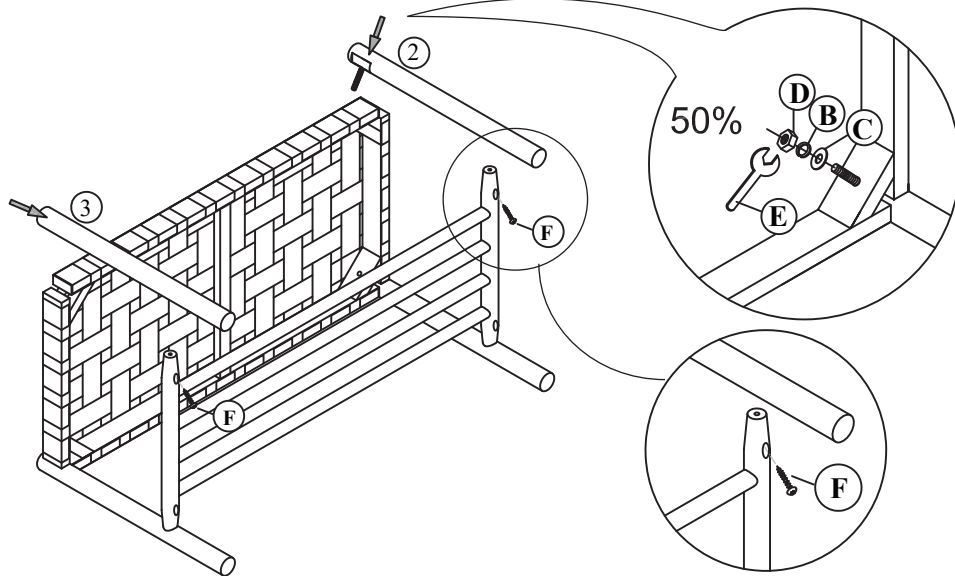

### STEP 4

Add felt pad (G) on leg bottom.

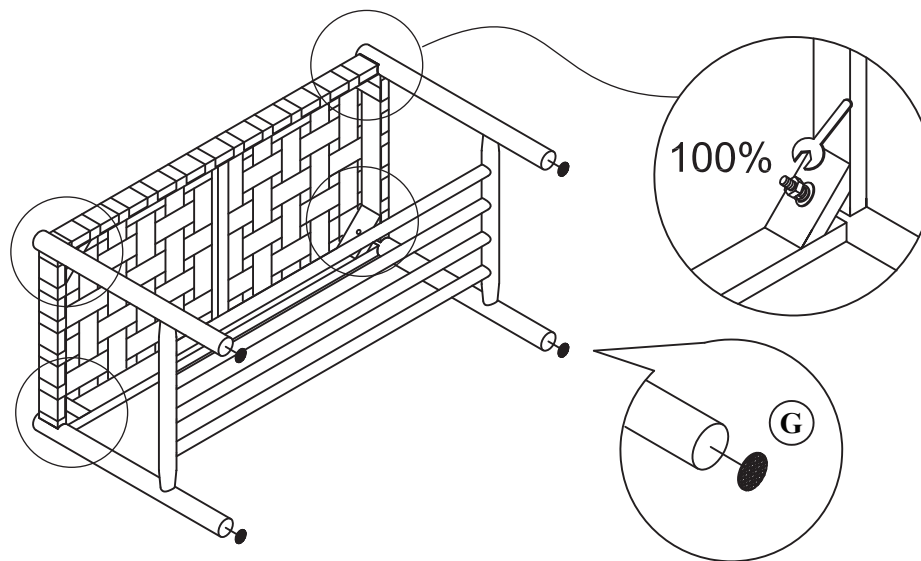

### STEP 5

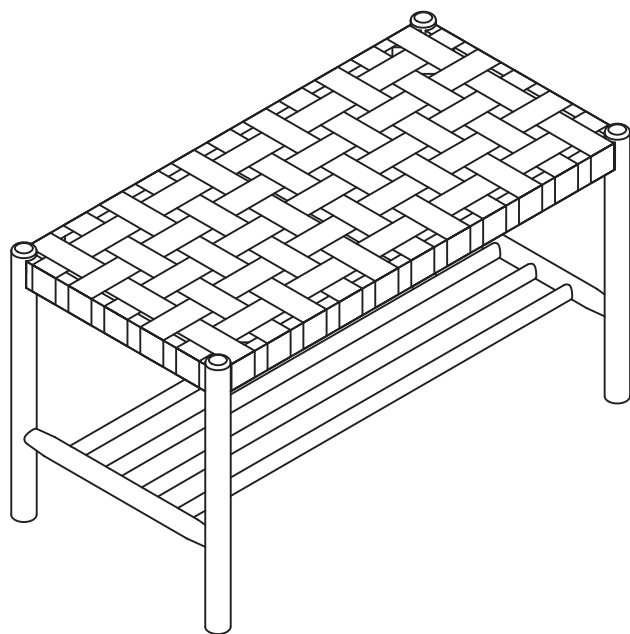

**ASSEMBLY COMPLETED**

NOTE : AFTER A FEW DAYS OF ASSEMBLY, IT WILL HAVE ACCLIMATIZED TO THE ENVIRONMENT. PLEASE TIGHTEN ALL HARDWARE.CHECK TIGHTNESS OF ALL SCREWS EVERY 6 - 8 WEEKS.